



# WM10N02G

## N-Channel MOSFET

### Features

- $V_{DS} = 100V$ ,  $I_D = 0.2A$   
 $R_{DS(on)} < 6\Omega$  @  $V_{GS} = 10V$   
 $R_{DS(on)} < 9\Omega$  @  $V_{GS} = 4.5V$
- High Speed Switch
- Load Switch Appliances
- Portable Appliances
- Halogen and Antimony Free, "Green" Device

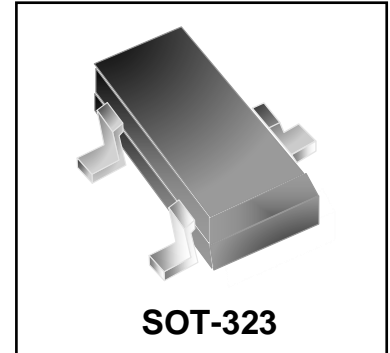

### Mechanical Characteristics

- SOT-323 Package
- Marking : Making Code
- RoHS Compliant

### Schematic & PIN Configuration

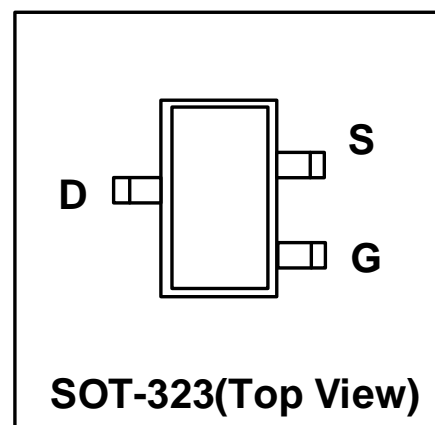
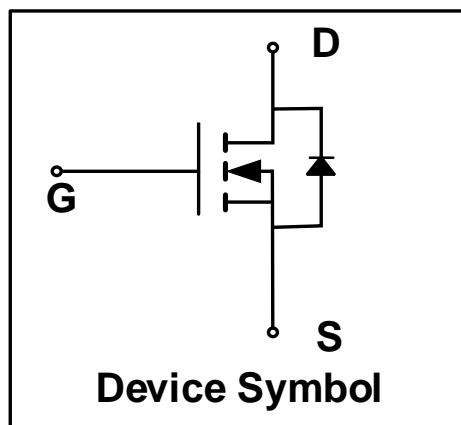

### Absolute Maximum Rating

| Parameter  | Symbol          | Value      | Unit          |
|--|-----------------|------------|---------------|
| Drain-Source Voltage                                     | $V_{DS}$        | 100        | V             |
| Gate-Source Voltage                                      | $V_{GS}$        | $\pm 20$   | V             |
| Continuous Drain Current                                 | $I_D$           | 0.2        | A             |
| Pulsed Drain Current <sup>1</sup>                        | $I_{DM}$        | 0.5        | A             |
| Power Dissipation  | $P_D$           | 200        | mW            |
| Junction Temperature                                     | $T_J$           | 150        | $^{\circ}C$   |
| Storage Temperature                                      | $T_{STG}$       | -55 to 150 | $^{\circ}C$   |
| Thermal Resistance from Junction to Ambient <sup>2</sup> | $R_{\theta JA}$ | 625        | $^{\circ}C/W$ |

Electrical Characteristics (T<sub>amb</sub>=25°C unless otherwise noted)

| Parameter                                     | Symbol                    | Test Condition  | Min. | Typ. | Max. | Unit |
|---|---------------------------|---|------|------|------|------|
| <b>Static Characteristics</b>                 |                           |   |      |      |      |      |
| Drain-Source Breakdown Voltage                | <b>BV<sub>DSS</sub></b>   | V <sub>GS</sub> = 0 V, I <sub>D</sub> = 250μA   | 100  | -    | -    | V    |
| Zero Gate Voltage Drain Current               | <b>I<sub>DSS</sub></b>    | V <sub>DS</sub> = 100V, V <sub>GS</sub> = 0 V   | -    | -    | 1    | μA   |
| Gate-body Leakage Current                     | <b>I<sub>GSS</sub></b>    | V <sub>DS</sub> = 0 V, V <sub>GS</sub> = ±20V   | -    | -    | ±1   | μA   |
| Gate Threshold Voltage <sup>3</sup>           | <b>V<sub>GS(th)</sub></b> | V <sub>DS</sub> = V <sub>GS</sub> , I <sub>D</sub> = 250μA                                  | 1    | -    | 3    | V    |
| Drain-Source On-state Resistance <sup>3</sup> | <b>R<sub>DS(on)</sub></b> | V <sub>GS</sub> = 10V, I <sub>D</sub> = 0.2A  | -    | 3.5  | 6    | Ω    |
|   |                           | V <sub>GS</sub> = 4.5V, I <sub>D</sub> = 0.17A  | -    | 3.8  | 9    |      |
| <b>Dynamic Characteristics</b>                |                           |   |      |      |      |      |
| Input Capacitance                             | <b>C<sub>iss</sub></b>    | V <sub>GS</sub> = 0V, V <sub>DS</sub> = 50V, f = 1MHz                                       | -    | 25   | -    | pF   |
| Output Capacitance                            | <b>C<sub>oss</sub></b>    |   | -    | 3.6  | -    |      |
| Reverse Transfer Capacitance                  | <b>C<sub>rss</sub></b>    |   | -    | 1.5  | -    |      |
| <b>Switching Characteristics</b>              |                           |   |      |      |      |      |
| Total Gate Charge <sup>4</sup>                | <b>Q<sub>g</sub></b>      | V <sub>GS</sub> = 10V, V <sub>DS</sub> = 10V, I <sub>D</sub> = 0.2A                         | -    | 1.5  | -    | nC   |
| Gate-Source Charge <sup>4</sup>               | <b>Q<sub>gs</sub></b>     |   | -    | 0.18 | -    |      |
| Gate-Drain Charge <sup>4</sup>                | <b>Q<sub>gd</sub></b>     |   | -    | 0.22 | -    |      |
| Turn-On Delay Time <sup>4</sup>               | <b>t<sub>d(on)</sub></b>  | V <sub>DD</sub> = 50V, V <sub>GS</sub> = 10V, I <sub>D</sub> = 0.2A,<br>R <sub>G</sub> = 6Ω | -    | 5.5  | -    | nS   |
| Turn-On Rise Time <sup>4</sup>                | <b>t<sub>r</sub></b>      |   | -    | 5.5  | -    |      |
| Turn-Off Delay Time <sup>4</sup>              | <b>t<sub>d(off)</sub></b> |   | -    | 7.8  | -    |      |
| Turn- Off Fall Time <sup>4</sup>              | <b>t<sub>f</sub></b>      |   | -    | 10   | -    |      |
| <b>Source-Drain Diode Characteristics</b>     |                           |   |      |      |      |      |
| Body Diode Voltage                            | <b>V<sub>SD</sub></b>     | I <sub>S</sub> = 0.2A, V <sub>GS</sub> = 0V   | -    | -    | 1.2  | V    |

**Notes:**

1. Repetitive Rating: Pulse width limited by maximum junction temperature.
2. Surface mounted on FR4 board using 1 square inch pad size, 1oz single-side copper.
3. Pulse Test: Pulse width ≤ 300μs, duty cycle ≤ 2%.
4. Guaranteed by design, not subject to product

Typical Characteristics

Figure 1. Output Characteristics

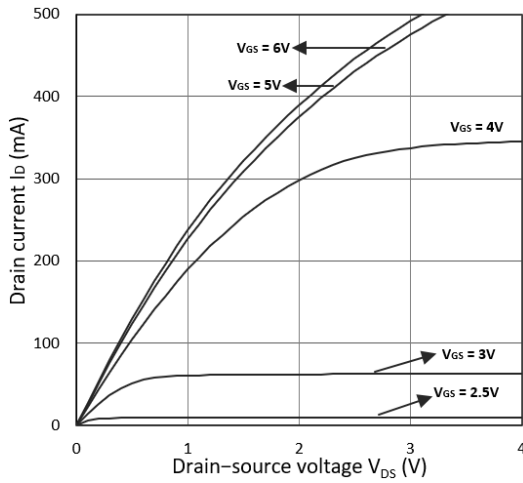

Figure 2. Transfer Characteristics

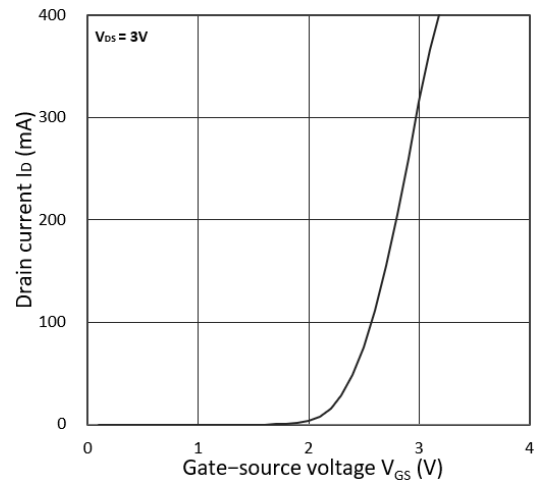

Figure 3.  $R_{DS(ON)}$  vs.  $I_D$

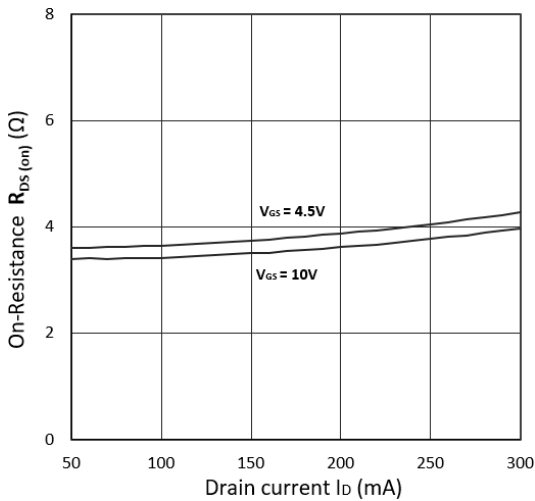

Figure 4.  $R_{DS(ON)}$  vs.  $V_{GS}$

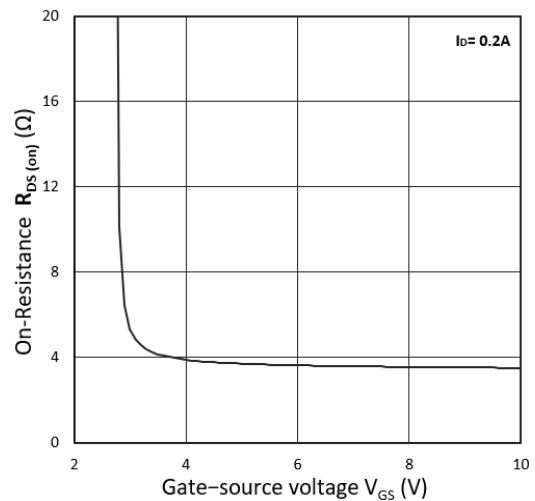

Figure 5.  $I_S$  vs.  $V_{SD}$

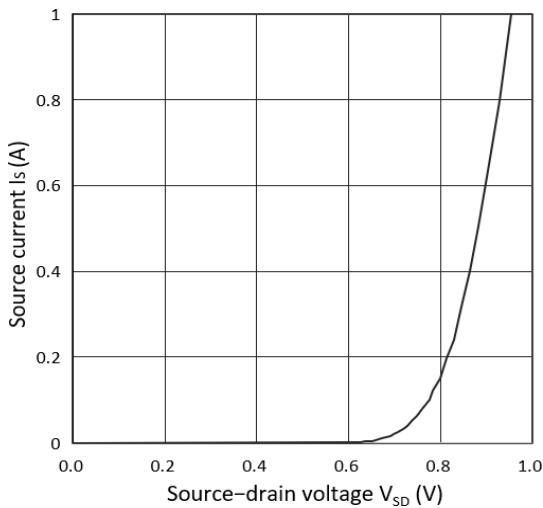
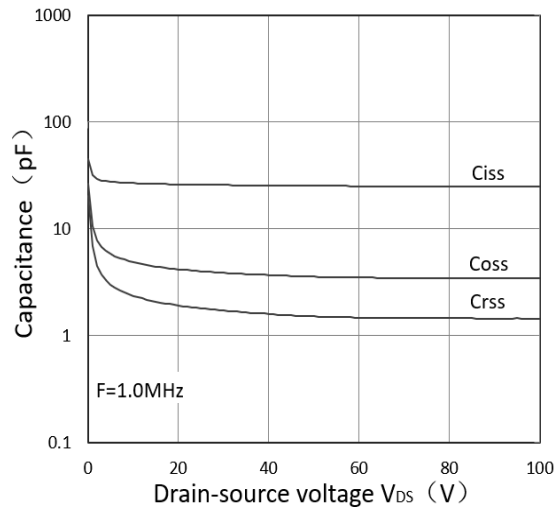

Figure 6. Capacitance Characteristics



Outline Drawing – SOT-323

**PACKAGE OUTLINE**

**SOT-323**

| SYMBOL | MILLIMETER |       | INCHES    |       |
|--------|------------|-------|-----------|-------|
|        | MIN.       | MAX.  | MIN.      | MAX.  |
| A      | 0.900      | 1.100 | 0.035     | 0.043 |
| A1     | 0.000      | 0.100 | 0.000     | 0.004 |
| D      | 2.000      | 2.200 | 0.079     | 0.087 |
| b      | 0.200      | 0.400 | 0.008     | 0.016 |
| c      | 0.080      | 0.150 | 0.003     | 0.006 |
| E      | 2.150      | 2.450 | 0.085     | 0.096 |
| E1     | 1.150      | 1.350 | 0.045     | 0.053 |
| e      | 0.650TYP   |       | 0.026TYP  |       |
| L      | 0.525 REF  |       | 0.021 REF |       |
| θ      | 0          | 8°    | 0         | 8°    |

| DIMENSIONS |        |             |
|------------|--------|-------------|
| DIM        | INCHES | MILLIMETERS |
| M          | 0.076  | 1.90        |
| C          | 0.036  | 0.9         |
| Z          | 0.108  | 2.7         |
| e          | 0.026  | 0.65        |
| e1         | 0.052  | 1.30        |
| b          | 0.028  | 0.7         |

**Notes**

1. Dimensioning and tolerances per ANSI Y14.5M, 1985.
2. Controlling Dimension: Inches
3. Pin 3 is the cathode (Unidirectional Only).
4. Dimensions are exclusive of mold flash and metal burrs.

Marking Codes

|              |          |
|--------------|----------|
| Part Number  | WM10N02G |
| Marking Code |          |

Package Information

Qty: 3k/Reel

CONTACT INFORMATION

No.1001, Shiwan (7) Road, Pudong District, Shanghai, P.R.China.201207

Tel: 86-21-68969993 Fax: 86-21-50757680 Email: [market@way-on.com](mailto:market@way-on.com)

WAYON website: <http://www.way-on.com>

For additional information, please contact your local Sales Representative.

**WAYON** ® is registered trademark of Wayon Corporation.

Specifications are subject to change without notice.  
The device characteristics and parameters in this data sheet can and do vary in different applications and actual device performance may vary over time.  
Users should verify actual device performance in their specific applications.